



FIXED-PITCH WOODEN PROPELLERS

DESIGNED
FOR
MAXIMUM
PERFORMANCE

SENSENICH WOOD PROPELLER CO.
2008 Wood Court
Plant City, Florida 33563

PHONE (813) 752-3711
FAX (813) 752-2818
<http://www.sensenich.com>

INSTALLATION LIST NO.612

Sensenich Fixed Pitch Wood Propellers Installation List for Type Certified Aircraft

Every effort has been made to list all planes and engines currently in use. If you do not find your propeller listed here, specify aircraft and engine model numbers when ordering a propeller. This list supersedes all previous lists and includes all recent design and designation changes. Be sure to check Hub Notes on last page before ordering.

Aircraft Make & Model	Engine Mfg.	Model	Horsepower	Standard Propeller	Climb Propeller	Cruise Propeller	Hub Note
Aeronca C3	Aeronca	E 113, A, B, C	36	W69A-28			6
Aeronca K	Aeronca	E 113, CB, CDB	40-45	W69A-30			6
Aeronca K C	Continental	A 40	40	W69J-28			8
Aeronca L B	Rearwin	5 DF, 5 F	85	W78R-54			33
Aeronca L C	Warner	Scarab Jr.	90	W80W			29
Aeronca K C A, 50C, 50TC	Continental	A 50	50	W76B-51	W76B-49		9
Aeronca 50 F	Franklin	4 AC 150	50	W70F-45		W70F-47	16
Aeronca L3A, B, C, E, F, J	Continental	A 65	65	W72CK-42		W72CK-44	1
Aeronca L3D	Franklin	4 AC 176	65	W72F-42		W72F-44	16
Aeronca L3G, H	Lycoming	O 145 B 2	65	W70LY-34		W70LY-36	12
Aeronca PT-23	Continental	R 670 5	220	W90LA-78			5
Aeronca 50F	Franklin	4 AC 150	50	W70F-45		W70F-47	16
Aeronca 50L, 50 LA, 50 TL	Lycoming	O 145 A 1	50	W70L-45		W70L-47	12
Aeronca 50L, 50 LA, 50 TL	Lycoming	O 145 A 2	55	W70L-47	W70L-45		12
Aeronca 60TF	Franklin	4 AC 150	60	W70F-47	W70F-45		16
Aeronca 65TC, 65TAC, O58, 65C, 65CA	Continental	A 65	65	W72CK-42		W72CK-44	1
Aeronca 50L, 50AL, 50TL (55 HP)	Lycoming	O 145 A 2	55	W70L-47	W70L-45		12
Aeronca 50L, 50AL, 50TL (50 HP)	Lycoming	O 145 A 1	50	W70L-45		W70L-47	12
Aeronca S 65 C, S 65 CA	Continental	A 65	65	W76CK-34		W76CK-36	1
Aeronca 65TL, 65TAL, 65LA, 65LB	Lycoming	O 145 B 2	65	W70LY-34		W70LY-36	12
Aeronca 65TF, 65TAF	Franklin	4 AC 176 B 2	65	W72F-42		W72F-44	16
Aeronca 7 AC, 11AC, 11ACS	Continental	A 65	65	W72CK-42		W72CK-44	1
Aeronca S7AC	Continental	A65	65	W76CK-34		W76CK-36	1
Aeronca 7BCM, 11BC	Continental	C 85	85	W72GK-46		W72GK-48	1
Aeronca 7DC, 11CC	Continental	C 85	85	W72GK-46		W72GK-48	1
Aeronca 15AC	Continental	C 145	145	W73BR-44			3
Aeronca 7EC, 7CCM	Continental	C 90	90	W72GK-48		W72GK-50	1
Bellanca 14 9 B	Rearwin	5 F, 5 G	90	W74B-58			33
Bellanca 14 12 F 3	Franklin	6 AC 264 F3	120	W74CF-57			19
Bellanca 14 13, 14 13 2	Franklin	6 A4 150 B3	150	W74RR-66			3
Bird B K	Kinner K5/100	K5	100	W90BA-49			37
Boeing PT 13 B, D, N 2 S-5	Lycoming	R 800 11	220	W98AA-66		W98AA-68	5
Boeing PT 17, A, N 2 S-3	Continental	R 670 5	220	W98AA-66		W98AA-68	5
Boeing PT 13, N2S375 Series	Lycoming	R 680 11	220-225	W98AA-66	W98AA-64	W98AA-68	5
Boeing PT 17, N3S375 Series	Continental	R 670 5	220	W98AA-66	W98AA-64	W98AA-68	5
Boeing PT 17, N2S375 Series (B HUB)	Continental	R 670 5	220	W98AB-66	W98AB-64	W98AB-68	22
Boeing PT 17, N2S375 Series (C HUB)	Continental	R 670 5	220	W98AC-66	W98AC-64	W98AC-68	11
Call A	Lycoming	O 235	100	W74FE-44		W74FE-46	14
Call A2	Lycoming	O 290	125	W76JB-48			15
Call A3	Continental	C 125	125	W76JR-48			3
Cessna C34, C37, C38, C145	Warner	Warner Super Scarab	145	W82R-81			37
Cessna C34, C37, C38, C145 (A HUB)	Warner	Warner Super Scarab	145	W82RA-81			35
Cessna C165	Warner	Warner Super Scarab	165	W82RA-81			35
Cessna T50, AT17	Jacobs	L 4 MB	225-245	W90JA-81			5
Cessna 120, 140	Continental	C 85	85	W72GK-48	W72GK-46		1
Cessna 140	Continental	C 90	90	W72GK-50			1
Cessna 170, 170A	Continental	C 145	145	W73BR-50			3

Aircraft Make & Model	Engine Mfg.	Model	Horsepower	Standard Propeller	Climb Propeller	Cruise Propeller	Hub Note
Cessna UC-78	Jacobs	L 4 MB	225-245	W90JA-81			5
Commonwealth	Continental	C 85	85	W72GK-46			1
Culver L C A	Continental	A 75	75	W70A-52		W70A-54	9
Culver L F A	Franklin	F 3	80	W70AF-54			16
Culver L F A	Franklin	4 AC 176 D 3	80	W70AF-52			16
Culver Dart	Lambert	R 266	90	W76D57			
Culver Dart GK3	Rearwin	5 F	90	W78R-54			
Daimond DA20C1	Continental	IO-240 B	125	W69EK7-63			38
Ercoupe	Continental	C 90	90	W72GK-50			
Ercoupe 415C	Continental	A 65	65	W72CK-42		W72CK-44	1
Ercoupe 415C,415CD,415D	Continental	C 75	75	W76RK-2-46		W76RK-2-48	1
Ercoupe 415D,E,G	Continental	C 85	85	W72GK-48		W72GK-50	1
Fairchild 24J, 24 W 40, 24G, 24W9, 24 W 41	Warner	Warner Super Scarab	145	W86C-67			37
Fairchild 24 J , 24 W 40, 24G, 24W9, 24 W 41 (A HUB)	Warner	Warner Super Scarab	145	W86CA-67		W86CA-69	35
Fairchild 24 W 40, 24 W 41 (A HUB)	Warner	Warner Super Scarab	145	W86CA-67		W86CA-69	35
Fairchild 24C8F, 24H	Ranger	6 390 D 3	150	W86BS-58			37
Fairchild 24C8F, 24H (A HUB)	Ranger	6 390 D 3	150	W86BAS-58			35
Fairchild 24K, 24R9, 24R9S	Ranger	6 410 B1, B2	165	W86BS-58	W86BS-55		37
Fairchild 24C8E, 24C8C	Warner	Warner Super Scarab	145	W86C-63			37
Fairchild 24C8E, 24C8C (A HUB)	Warner	Warner Super Scarab	145	W86CA-63			35
Fairchild 24 Seaplane	Warner	Warner Super Scarab	145	W86C-63			37
Fairchild 24 Seaplane (A HUB)	Warner	Warner Super Scarab	145	W86CA-63			35
Fairchild 24C8F, 24C8D	Ranger	6 390 B, D, D 3	145	W86BS-53			37
Fairchild 24C8F, 24C8D (A HUB)	Ranger	6 390 B, D, D 3	145	W86BAS-53			35
Fairchild 24 R 40	Ranger	6 410 B 3	175	W86BS-55			37
Fairchild 24 R 40 (A HUB)	Ranger	6 410 B 3	175	W86BAS-55			35
Fairchild M 62A, PT-19	Ranger	6 440 C 3	180	W86R-61	W86R-58		35
Fairchild M 62A, PT-19 (A HUB)	Ranger	6 440 C 3	180	W86RA-61	W86RA-58		5
Fairchild M 62A 3	Ranger	6 440 C 5	200	W86R-61	W86R-58		35
Fairchild M 62 B (A HUB)	Warner	Warner Super Scarab 165	165	W86CA-69			35
Fairchild M 62 B (B HUB)	Warner	Warner Super Scarab 165	165	W86CB-69			36
Fairchild PT-23, M 62 C	Continental	W 670	220	W90LA-78			5
Fairchild PT-19A,B	Ranger	6 440 C 2	180	W86R-61			35
Fairchild PT-19A, B (A HUB)	Ranger	6 440 C 2	180	W86RA-61			5
Fairchild PT-19A, B (B HUB)	Ranger	6 440 C 2	180	W86RB-61			36
Fairchild PT-26	Ranger	6 440 C 5	200	W86R-61			35
Fairchild PT-26 (A HUB)	Ranger	6 440 C 5	200	W86RA-61			5
Fairchild PT-26 (B HUB)	Ranger	6 440 C 5	200	W86RB-61			36
Fairchild M 62A 3 (A HUB)	Ranger	6 440 C 5	200	W86RA-61	W86RA-58		5
Fairchild UC-61 (B HUB)	Warner	Warner Super Scarab 165	165	W86CB-69			36
Fairchild C 61,24W41A (A HUB)	Warner	Warner Super Scarab 165	165	W86CA-69			35
Fairchild UC-61K, 24R46A (B HUB)	Ranger	6 440 C 5	200	W86AB-54			36
Fairchild C 61 (B HUB)	Ranger	6 440 C 5	200	W86AB-54			36
Fairchild UC-61 (A HUB)	Warner	Warner Super Scarab 165	165	W86CA-69			35
Fairchild 24W46, C 61, 24W41A (B)	Warner	Warner Super Scarab 165	165	W86CB-69			36
Fairchild 24R46	Ranger	6 440 C 3	175	W86RB-60			36
Fairchild 24R46 Seaplane	Ranger	6 440 C 3	175	W86BB-55			36
Fleet 1	Warner	Warner Scarab	125	W90BA-45			37
Fleet 7, 8, 9, 10, 16B	Kinner	B 5	125	W90D-67			24
Fleet 7, 8, 9, 10, 16B (A HUB)	Kinner	B 5	125	W90DA-67			26
Fleet 2	Kinner	K 5	100	W90BA-49			37

Aircraft Make & Model	Engine Mfg.	Model	Horsepower	Standard Propeller	Climb Propeller	Cruise Propeller	Hub Note
Fleet 80 Canuck	Continental	C 85	85	W72GK-46			1
Fleet 80 Canuck Seaplane	Continental	C 85	85	W76RK-40			1
Fleet PT-23	Continental	R 670 5	220	W90LA-78			5
Fleet PT-19A	Ranger	6 440 C 2	180	W86R-61			35
Fleet PT-19A (A HUB)	Ranger	6 440 C 2	180	W86RA-61			5
Fleet PT-19A (B HUB)	Ranger	6 440 C 2	180	W86RB-61			36
Fleet PT-23	Continental	R 670 5	220	W90LA-78			5
Fleet PT-26	Ranger	6 440 C 5	200	W86R-61			35
Fleet PT-26 (A HUB)	Ranger	6 440 C 5	200	W86RA-61			5
Fleet PT-26 (B HUB)	Ranger	6 440 C 5	200	W86RB-61			36
Funk B	Funk	E	63	W755CF-40			20
Funk B 75 L	Lycoming	GO 145 C	75	W76L-56			13
Funk B 85 C	Continental	C 85	85	W72GK-48			1
Globe Swift GC 1 B (R HUB)	Continental	C 125	125	W73BR-54			3
Globe Swift GC 1 B (G HUB)	Continental	C 125	125	W73BG-54			10
Great Lakes R755 (A HUB)	Jacobs	R-755B2M	225, 245, 275	W96JA-4-68		W90T6JA-72	5
Great Lakes R755 (B HUB)	Jacobs	R-755B2M	225, 245, 275	W96JB-4-68		W90T6JB-72	22
Grumman Widgeon G 44, G44 A	Ranger	6 440 C 5	200	W82RS-72			35
Grumman OA 14	Ranger	6 440 C 5	200	W82RS-72			35
Howard PT-23	Continental	R 670 5	220	W90LA-78			5
Interstate S 1 A	Continental	A 65	65	W72CK-44	W72CK-42		1
Interstate S 1 A 65 F	Franklin	4 AC 176 B 2	65	W72F-44	W72F-42		16
Interstate S 1 A 90 F	Franklin	4 AC 199 E 2	90	W72DF-49	W72DF-48		17
Luscombe Phantom 1	Warner	Warner Super Scarab	145	W86C-69			37
Luscombe 8 A	Continental	A 65	65	W76CK-42		W76CK-44	1
Luscombe 8 A Seaplane	Continental	A 65	65	W76CK-38		W76CK-40	1
Luscombe 8 B	Lycoming	O 145 B	65	W70LY-38			12
Luscombe 8 C, 8 D	Continental	A 75	75	W72GK-46		W72GK-48	1
Luscombe 8 E	Continental	C 85	85	W72GK-48		W72GK-50	1
Luscombe 8	Continental	A 50	50	W76B-51			9
Luscombe 8 F	Continental	C 90	90	W72GK-50			1
Luscombe 11 A	Continental	E 165	165	W80EY-80			4
McCulloch J-2	Lycoming	O 360	180	W72KZL-52	W72KZL-49		49
Meyers OTW 120	Warner	Warner Scarab	125	W90BA-45			37
Meyers OTW 145	Warner	Warner Super Scarab	145	W90BA-50	W90BA-48		35
Meyers OTW 160	Kinner	R 56	160	W92H-76			23
Mooney M-18C/C 55	Continental	A-65	65	W65CK-60	W65CK-58	W65CK-62	1
Mooney M-18L/LA	Lycoming	O 145 B	65	W66CB-54, W60MY-49			12
Monocoupe 90, 90A	Lambert	R 266	90	W76D-57			
Monocoupe 90 A F	Franklin	4 AC 199	90	W74FDS-45			17
Piper E 2	Continental	A 40	40	W69C-23		W69C-26	8
Piper J 2, J 3	Continental	A 40	40	W69C-23		W69C-25	8
Piper J 3	Continental	C 75	75	W72GK-50	W72GK-48		
J3	Continental	C 85	85	W72GK-46	W72GK-44		
Piper J 3	Continental	C 90	90	W72GK-48			
Piper J 3 C 50	Continental	A 50	50	W76B-47		W76B-49	9
Piper J 3 C 65	Continental	A 65	65	W72CK-42	W72CK-40	W72CK-44	1
Piper J 3 C 65 Duster	Continental	A 65	65	W72CK-40			1

Aircraft Make & Model	Engine Mfg.	Model	Horsepower	Standard Propeller	Climb Propeller	Cruise Propeller	Hub Note
Piper J 3 C 75 Duster	Continental	A 75	75	W70DK-40			9
Piper J 3 Duster & Sprayer	Continental	C 85	85	W72GK-44			1
Piper J 3 C 65 S	Continental	A 65	65	W76CK-34		W76CK-36	1
Piper J 3 F 50	Franklin	4 AC 150	50	W70F-43		W70F-45	16
Piper J 3 F 60	Franklin	4 AC 171, 4 AC	150	W70F-47			16
Piper J 3 F 65	Franklin	4 AC 176 B	65	W72F-42		W72F-44	16
Piper J 3 L (50 HP)	Lycoming	O 145 A 1	50	W70L-43		W70L-45	12
Piper J 3 L (55 HP)	Lycoming	O 145 A 2	55	W70L-45		W70L-47	12
Piper J 3 L 65	Lycoming	O 145 B	65	W70LY-34		W70LY-36	12
Piper J 3 L 65 S	Lycoming	O 145 B	65	W70LY-32			12
Piper J 4	Continental	A 50	50	W76B-47		W76B-49	9
Piper J 4	Continental	C 85	85	W76RK-2-46	W76RK-2-44		
Piper J 4 A	Continental	A 65	65	W72CK-42		W72CK-44	1
Piper J 4 B	Franklin	4 AC 171	60	W70F-47			16
Piper J 4 E	Continental	A 75	75	W70DK-42	W70DK-40	W70DK-44	9
Piper J 4 F	Lycoming	O 145 B	65	W70LY-36	W70LY-34		12
Piper J 5 A	Continental	A 75	75	W70DK-40		W70DK-42	9
Piper J 5 B	Lycoming	GO 145 C	75	W78LY-52			13
Piper A E 1, J 5 C	Lycoming	O 235	100	W74FE-46	W74FE-44		14
Piper L 4, A, B, H	Continental	A 65	65	W72CK-42			1
Piper L 4C	Lycoming	O 145 B 2	65	W70LY-34			12
Piper L 4D	Franklin	4 AC 176 B 2	65	W72F-42			16
Piper L 4E, F	Continental	A 75	75	W70DK-42		W70DK-44	9
Piper L 4G	Lycoming	GO 145 C 3	75	W78LY-52			13
Piper L 14	Lycoming	O 290	125	W76JB-44			15
Piper PA-11, PA-17	Continental	A 65	65	W72CK-42	W72CK-40	W72CK-44	1
Piper PA-11, PA-18	Continental	C 90	90	W76CK-40	W76CK-38	W72GK-52	1
Piper PA-11 Seaplane (65 HP)	Continental	A 65	65	W76CK-34		W76CK-36	1
Piper PA-11 Seaplane (90 HP)	Continental	C 90	90	W76CK-36			1
Piper PA-12	Lycoming	O 235 C	100	W76RM-44	W76RM-43		2
Piper PA-12 (108 HP)	Lycoming	O 235 C 1	108	W76RM-46			2
Piper PA-12 Seaplane	Lycoming	O 235 C	100	W76RM-41			2
Piper PA-12 125 HP	Lycoming	O 290	125	W80DM-34	W80DM-32	W80DM-36	stc 01
Piper PA-12 135 HP	Lycoming	O 290 D 2	135	W80DM-36	W80DM-34	W80DM-38	stc 01
Piper PA-12 145 HP	Continental	O-300 A, B or C145	125, 165	W80DR-38	W80DM-36	W80DM-40	stc 01
Piper PA-12 150 HP	Lycoming	O 320	150	W80DM-40	W80DM-38	W80DM-42	stc 01
Piper PA-12 160 HP	Lycoming	O 320	160	W80DM-42	W80DM-40	W80DM-44	stc 01
Piper PA-14, PA-16, PA-18, PA-20	Lycoming	O 235 C 1	108	W76RM-2-46	W76RM-2-44		2
Piper PA-15	Lycoming	O 145 B	65	W70LY-36		W70LY-38	12
Piper PA-20, PA-22 125	Lycoming	O 290 D	125	W74FM-54			2
Piper PA-20, PA-22 135	Lycoming	O 290 D 2	135	W74FM-54			2
Piper PA-18, PA-18 A	Lycoming	O 290 D	125	W74FM-47	W74FM-45		2
Piper PA-18, PA-18 A (135 HP)	Lycoming	O 290 D 2	135	W74FM-49	W74FM-47		2
Piper PA-18 125 HP	Lycoming	O 290 D 2	125	W80DM-34	W80DM-32	W80DM-36	stc01, 02
Piper PA-18 135 HP	Lycoming	O 290 D 2	135	W80DM-36	W80DM-34	W80DM-38	stc01, 02
Piper PA-18 145 HP	Continental	O 300 A, B or C145	125, 165	W80DR-38	W80DM-36	W80DM-40	stc01, 02
Piper PA-18 150 HP	Lycoming	O 320	150	W80DM-40	W80DM-38	W80DM-42	stc01, 02
Piper PA-18 160 HP	Lycoming	O 320	160	W80DM-42	W80DM-40	W80DM-44	stc01, 02
Piper PA-18 180 HP	Lycoming	O 360	180	W80CM8-46	W80CM8-44	W80CM8-48	Stc 02
Porterfield 35 70	Rearwin	5 D E	70	W78R-50			33
Porterfield 35 W	Warner	Warner Scarab Jr	90	W80W			29
Porterfield C P 50, C P 55	Continental	A 50	50	W76B-49	W76B-47		9
Porterfield C P 65	Continental	A 65	65	W72CK-44	W72CK-42		1
Porterfield F P 65	Franklin	4 AC 176 B 1	65	W72F-46	W72F-44		16
Porterfield LP 65	Lycoming	O 145 B	65	W70LY-38	W70LY-36		12

Aircraft Make & Model	Engine Mfg.	Model	Horsepower	Standard Propeller	Climb Propeller	Cruise Propeller	Hub Note
Rearwin 7000	Rearwin	5 D E	70	W78R-50			33
Rearwin 8125, 8135, 8135T	Rearwin	7 F, 7 G	120	W78R-57		W78R-59	33
Rearwin 8500, 9000 KR, 9000 L	Rearwin	5 G	85-90	W78R-50			33
Rearwin 165	Continental	A 65	65	W72CK-44	W72CK-42		1
Rearwin 175	Continental	A 75	75	W70DK-44	W70DK-42		9
Rearwin 180 F	Franklin	4 AC 176 F 3	80	W70DF-48			16
Ryan PT 22 (B HUB)	Kinner	R 56	160	W90HB-86			24
Ryan PT 22	Kinner	R 56	160	W90H-86			28
Ryan PT 22 (A HUB)	Kinner	R 56	160	W90HA-86			5A
Ryan S T A	Menaso	C 4/124	125	W80R-70			31
Ryan SCW 145 (A HUB)	Warner	Warner Super Scarab	145	W82RA-77			35
Ryan SCW 145	Warner	Warner Super Scarab	145	W82R-77			37
Ryan S T 3 K R	Kinner	R 56	160	W90H-86			28
Ryan S T 3 K R (A HUB)	Kinner	R 56	160	W90HA-86			5A
St. Louis PT-23	Continental	R 670	220	W90LA-78			5
Stinson 10, HW-75	Continental	A 75	75	W70DK-40		W70DK-42	9
Stinson 10, 105, HW-80	Continental	A 80	80	W70DK-42	W70DK-40		9
Stinson 10 A	Franklin	4 AC 199 E 2	90	W72DF-48		W72DF-49	17
Stinson L 5	Lycoming	O 435	190	W85RW-57			35
Stinson L 5	Lycoming	O 435	190	W85RB-57			36
Stinson L 9A, B	Franklin	4 AC 199 E 3	90	W72DF-48		W72DF-49	17
Stinson 108	Franklin	6A4 150 B31	150	W76JA-53			18
Stinson 108, 108-1	Franklin	6A4 150 B3	150	W76JR-53		W76JR-55	3
Stinson 108, 108-1 Seaplane	Franklin	6A4 150 B3	150	W76JR-51		W76JR-53	3
Stinson 108-2, 108-3	Franklin	6A4 165 B3	165	W76JR-53		W76JR-55	3
Stinson 108-2 Seaplane	Franklin	6A4 165 B3	165	W76JR-51		W76JR-53	3
Taylorcraft A	Continental	A 40	40	W69J-28			8
Taylorcraft BC-65, BC-12 65, L2	Continental	A 65	65	W72CK-42		W72CK-44	1
Taylorcraft BC-12D, BC-12D1	Continental	A 65	65	W72CK-42		W72CK-44	1
Taylorcraft BCS-12D, BCS-65	Continental	A 65	65	W76CK-34		W76CK-36	1
Taylorcraft BCS-1265, BCS-12D1	Continental	A 65	65	W76CK-34		W76CK-36	1
Taylorcraft BF	Franklin	4 AC 150	50	W70F-45	W70F-43		16
Taylorcraft BF-65, BF-1265	Franklin	4 AC 176 B 2	65	W72F-42		W72F-44	16
Taylorcraft BF-65, BF-1265, DL-65	Lycoming	O 145 B	65	W70LY-36	W70LY-34	W70LY-38	12
Taylorcraft DC-65, DCO-65	Continental	A 65	65	W72CK-42		W72CK-44	1
Taylorcraft DF-65	Franklin	4 AC 176	65	W72F-42		W72F-44	16
Taylorcraft BC12D85, BC12D485	Continental	C 85	85-90	W72GK-48		W72GK-50	1
Taylorcraft L2A, B, H, M	Continental	A 65	65	W72CK-42		W72CK-44	1
Taylorcraft L2D, F, J	Lycoming	O 145 B 2	65	W70LY-36	W70LY-34	W70LY-38	12
Taylorcraft L2E, K	Franklin	4 AC 176 B 2	65	W72F-42		W72F-44	16
Taylorcraft L2G, L	Franklin	4 AC 150	50	W70F-45	W70F-43		16
Taylorcraft 19	Continental	C 85	85-90	W72GK-46		W72GK-48	1
Waco RNF, RBA	Warner Scarab	Warner Scarab	125	W90BA-45			37
Waco UKC, UIC, UBA, UEC	Continental	R 670 A	210	W100CC-65			11
Waco YPT-14, UPF-7, UIC	Continental	W 670 BA	225	W98C-70	W98AC-68		11
Waco YMF, YQC, YOC, YKS, YKC	Jacobs	L 4	225	W100CD-67			23
Waco QCK, QDC, QSO	Continental	A 70, A70 2	165	W100CC-58			11
Waco YMF5 (A HUB)	Jacobs	R-755B2M	225, 245, 275	W96JA-4-68		W90T6JA-72	5
Waco YMF5 (B HUB)	Jacobs	R-755B2M	225, 245, 275	W96JB-4-68		W90T6JB-72	22
Waco YMF5FC (A HUB)	Jacobs	R-755B2M	225, 245, 275	W96JA-4-68			5
Waco YMF5FC (B HUB)	Jacobs	R-755B2M	225, 245, 275	W96JB-4-68			22

Hub Note	Manufacturer	Type	Hub Model	Hub Thickness in Inches	Bore	Circle Dia.	Bolt No.	Dia. Of Bolt Holes
1	Engine Manufacturer	Integral Flange	SAE #1 Flange (Taper use A437 Bushings)	3.375	2.255	4.375	6.000	0.375
2	Engine Manufacturer	Integral Flange	SAE #2 Flange	3.500	2.255	4.750	6.000	0.375
3	Engine Manufacturer	Integral Flange	SAE #3 Flange	4.000	2.255	5.250	8.000	0.375
4	Engine Manufacturer	Integral Flange	SAE #4 Flange	5.000	2.255	6.000	8.000	0.438
5	Air Force	SAE 20 Spline	41G2325-9	6.000	3.880	7.000	8.000	0.438
5A	Air Force	SAE 20 Spline	41G2325-6	5.250	3.880	7.000	8.000	0.438
6	Aeronca	Taper	805	2.500	1.755	5.000	6.000	0.375
8	Continental	SAE No. 0 Taper	A3482	3.250	2.255	4.000	6.000	0.375
9	Continental	SAE No. 0 Taper	A3746	3.375	2.255	4.375	6.000	0.375
10	Continental	SAE 10 Spline	A40611	4.000	2.755	5.250	8.000	0.375
11	Continental	SAE 20 Spline	A4064	6.000	3.151	6.693	8.000	0.500
12	Lycoming	Integral Flange		3.250	1.875	4.375	6.000	0.375
13	Lycoming	Integral Flange		3.500	1.875	4.750	6.000	0.375
14	Lycoming	Integral Flange		4.000	2.192	4.750	6.000	0.375
15	Lycoming	Integral Flange		4.000	2.192	5.250	8.000	0.375
16	Franklin	Integral Flange		3.250	2.005	4.000	6.000	0.375
17	Franklin	Integral Flange		4.000	2.005	4.000	6.000	0.375
18	Franklin	Integral Flange		4.000	2.005	5.000	8.000	0.375
19	Franklin	Integral Flange		4.000	2.005	5.000	8.000	0.438
20	Funk	Taper		4.000	2.380	4.688	6.000	0.375
22	Jacobs	SAE 20 Spline	90205	6.000	3.817	6.693	8.000	0.658
23	Jacobs	SAE 20 Spline		6.000	3.443	6.693	8.000	0.500
24	Kinner	SAE No. 1 Taper	610	4.000	2.692	5.250	8.000	0.375
26	Kinner	SAE 10 Spline	1475	4.000	3.255	5.250	8.000	0.375
27	Kinner	SAE 10 Spline	1475	4.000	3.255	5.250	8.000	0.438
28	Kinner	SAE 20 Spline	1609, 42K14179	4.000	4.130	6.250	8.000	0.438
29	Menasco	Taper Shaft	2016A	4.000	2.692	5.250	8.000	0.375
31	Menasco	(Propeller Model W80R)		4.375	2.949	5.250	8.000	0.375
33	Rearwin	Leblond No. 1 Taper	5057	4.000	2.692	4.625	6.000	0.438
35	Warner	SAE 20 Spline	7900, 8350, 8599	4.125	3.255	5.250	8.000	0.375
36	Warner	SAE 20 Spline	8808, 43D24385	4.125	3.255	6.188	6.000	0.375
37		SAE No. 1 Taper	OX5	4.000	2.692	5.250	8.000	0.375
38	Special	Flange Adapter	SAE #1 Flange with 7/16" bolts	3.190	2.255	4.375	6.000	0.438
39	Special	Flange Adapter	SAE #6	3.630	2.255	4.750	6.000	0.500

Supplemental Type Certificate Notes:

STC 01	Piper	PA-12/PA-18	Aircraft Restoration Supplies Belle Plaine, MN (612) 873-6659
STC 02	Piper	PA-18	Cubcrafters Yakima, WA (509) 248-9591

Is Your Wood Propeller Properly Torqued?

Why does your wood propeller lose bolt torque?

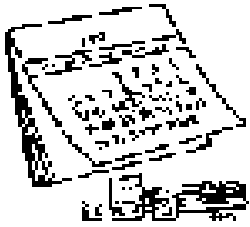

Your wood propeller is a living, breathing piece of wood that will change dimensionally over time and with temperature and humidity. A one percent decrease in moisture content will cause a 3-1/2" hub to shrink by .011".

Why looks can be deceiving.

300 in-lbs



175 in-lbs



One of these look-alike propellers has lost its bolt torque.

Use your torque wrench, not your eyes to know if your propeller is properly torqued.

Why proper bolt torque is so important.

Friction drives your propeller.

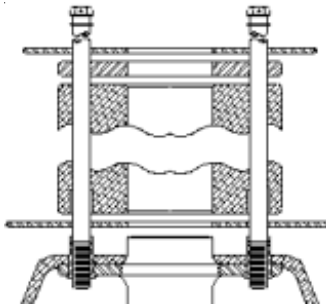

It is the friction between the propeller hub and the engine flange, supplied by proper bolt torque that drives your propeller. The drivelugs do not physically drive the propeller.

Low bolt torque generates heat.



Charred prop hub

The loss of bolt torque induces heat due to the propeller rubbing back and forth on the flange when the engine fires. This results in rapid drying and shrinking of the wood and further accelerates bolt torque loss.

Overtorquing can cause damage.



Over torqued prop hub

A crushed hub breaks the moisture seal and allows moisture to penetrate the hub, which increases hub swelling and accelerates wood rot.

Proper propeller maintenance will save you money.



A propeller that is properly maintained will help prevent broken bolts and cracked hubs. Be sure to read and understand the Use and Care Instructions that come with your propeller. Always check your propeller as instructed before starting your engine.

Remember....check your bolt torque every 50 hours or change of seasons!

